

No.	Description	Quantity
1	Booster Delete Adapter	1
2	Master Cylinder Spacer	1
3	Master Cylinder Pushrod Adapter	1
4	Pushrod	1
5	Drill Template	1
6	M8 x 20mm Hex Head Screw	1
7	M8 Hex Nut	1
8	10mm Vacuum Cap	1
9	M8 x 61 Studs	2
10	M8 x 55 Studs	4
11	Vibra-tite Thread Locker	1
12	Firewall Gasket	1
13	½" UNF Hex Head Bolt 3.25" long	1
14	½ Flat Washer	1
15	½ UNF Half Nyloc	1

1. Remove the driver's seat
2. Remove the dash underside cover in drivers footwell
3. In the engine bay, remove the upper cowl panel and wiper motor etc
4. Unbolt the clutch reservoir and cable tie it out of the way
5. Drain the original master cylinder reservoir (using a syringe or similar)
6. Disconnect vacuum hose that runs from booster to intake manifold, discard hose, keep one of the hose clamps. Remove the master cylinder, take precautions not to spill any remaining brake fluid. Just push the brake lines gently out of the way. Retain the original spring washers and nuts.
7. Fit the supplied 10mm rubber block off cap to the now unused barb fitting on intake manifold, reuse the hose clamp.
8. Prepare the firewall adapter. Apply Vibra-tite thread locker to the end of each m8 stud, you want to apply this to the end of the stud with the shorter thread. Then install the studs as shown below. After threading in by hand, we suggest tightening the studs in place with a set of long nose pliers or vice grips holding onto the non-threaded section of the stud. Reference photo at the end of this document.

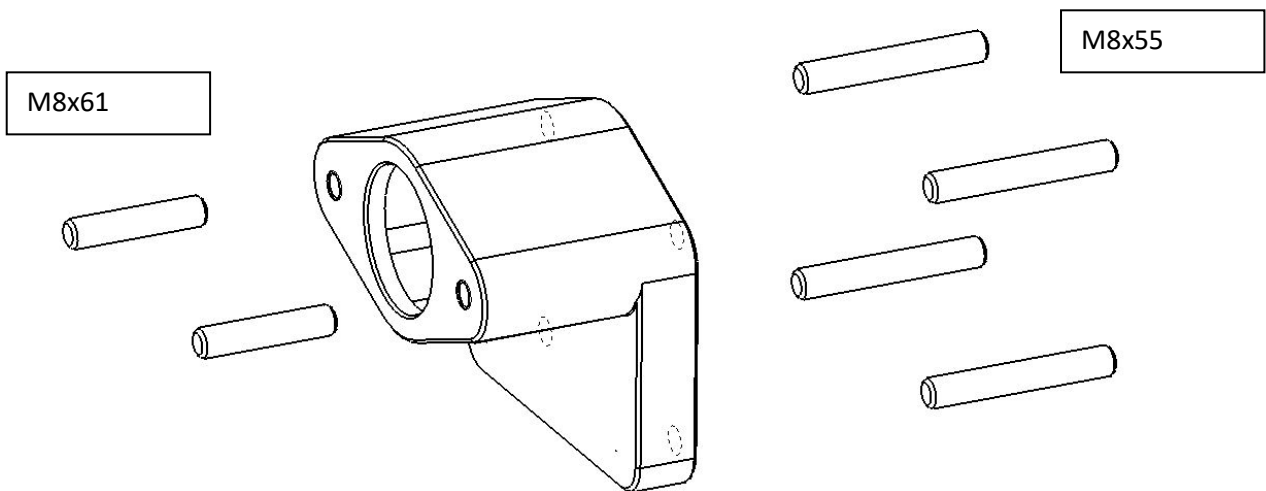

9. In the driver's side footwell, remove split pin from brake pedal clevis pin and remove the pin.
10. Remove the four nuts on the inside of the firewall that retain the booster and remove booster from engine bay side.
11. Remove the brake pedal assembly from the car, there is a brace that must be removed to get this out
12. **Remove the brake pedal from the pedal assembly. Refer to reference photos below.**
13. Drill an 8mm hole in the brake pedal 25mm (1") up from the original hole, using the provided template (refer to photo). The template is bolted to the original mounting hole, and then pivoted until the edge of the template aligns with the edge of the pedal. Drill hole initially with 3mm or equivalent pilot hole, then drill to final size with 8mm drill bit.
14. Modify the pedal bracket assembly in order to re-mount the pedal to the pedal bracket. Drill the pedal pivot hole out to 13mm on each side, de-burr the holes and if you are in an area where rust is an issue, paint any exposed metal.
15. Use the provided 1/2" bolt as the new pedal pivot shaft, apply a light coat of grease to the bolt before installing. Refer to photo section below for more instructions.
16. Remove clevis and jam nut from the brake booster. Assemble jam nut and clevis to the supplied pushrod. Leave the jam nut a half turn off the clevis for now.
17. Mount the supplied adapter to the firewall as per the original booster mounting. Attach the firewall gasket to the firewall side of the adapter. Re-use the OEM M8x1.25 nuts. Reinstall the brake pedal assembly.

18. Put the supplied master cylinder spacer on the front of the firewall adapter.
19. Insert the pushrod from the engine bay side and attach to the pedal with the clevis, and OEM pin and clip through the newly created hole. Push the pedal to the floor so that the push rod is extended through the adapter.
20. Have the pushrod adjusted towards the pedal in it's adjustment range to begin with then offer the new master cylinder up to the pushrod taking care to ensure that the push rod is engaged into the centre of the master cylinder correctly
21. Attach the master cylinder to the adapter using the two OEM M8x1.25 nuts. At this point cycle the pedal through its full travel to check for free travel and no binding in the pushrod clevis. **Tighten all M8 hardware to 15Nm (11 ftlb)**
22. The OE brake lines can be gently bent into position to suit the master cylinder in its new position.
23. Adjust the pushrod so minimal play exists at the top of the travel, and check that the brake light switch is correctly activated when pedal is pressed. You can wind the pushrod towards the master with your fingers then when ready to lock in position, use a 12mm spanner to lock the jam nut against the clevis. Aim to have the brake pedal at the same height as the clutch pedal but if this feels too high you may need to adjust it after test driving. Adjust the pushrod and brake light switch at the same time to raise or lower the pedal starting height.
24. Mount reservoir bracket
25. Mount brake and clutch reservoirs
26. Bleed the braking system. **Bleeding the brake system may take longer than previously, due to the lesser stroke of the master cylinder due to the change in pedal ratio.**

Removing the Pedal and Pedal Modifications:

To remove the pedal from the pedal assembly, grind down the deformed end of the original pivot bolt then press/punch the pivot stud out off the bracket.

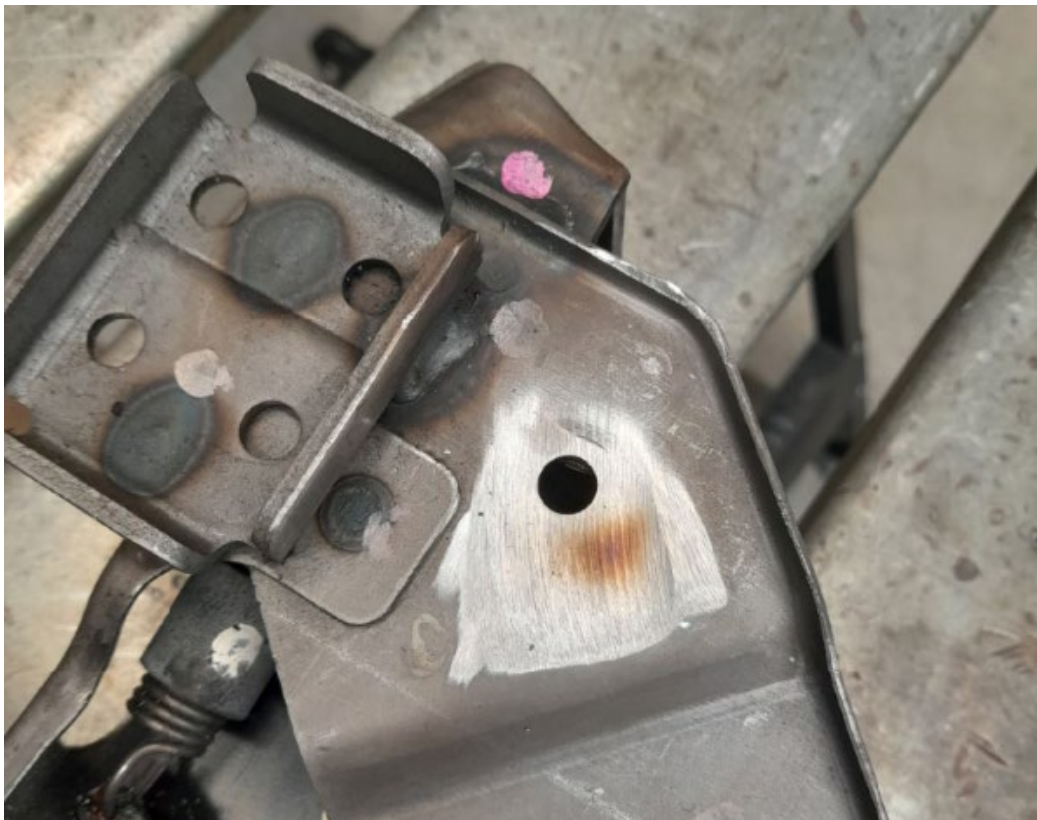

Pull the pedal out and apply drilling template. Drill new 8mm pivot hole and clearance the pedal so that the clevis can rotate freely. The drilling template also indicates the material to remove.

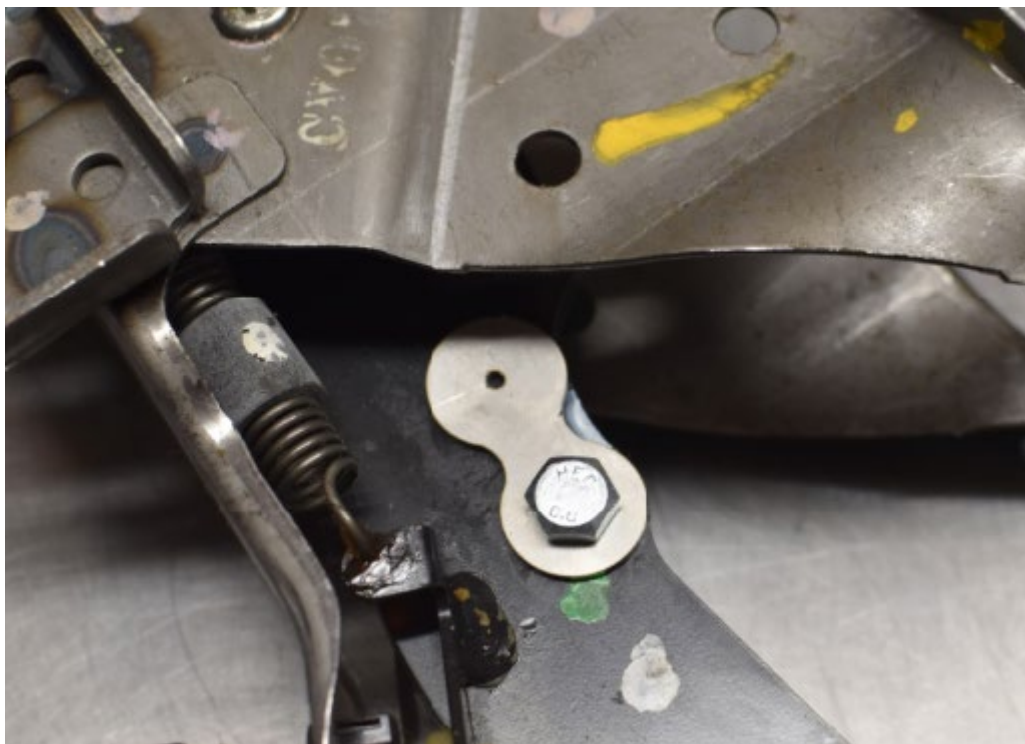

Pedal with new clevis pivot hole and new shape after grinding for clearance for clevis rotation.

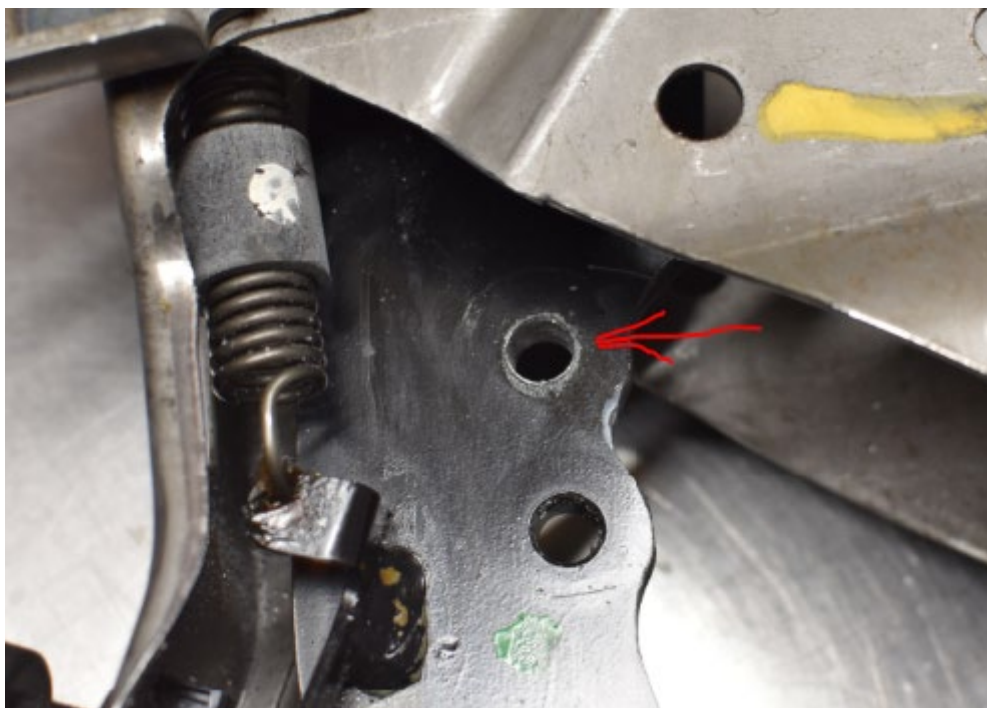



Replacing the Pedal Pivot

You may need to de-bur the pedal pivot bushes to get the new bolt through.



Apply a light coating of grease to the new pedal pivot bolt.



Take care not to over-tighten this pivot bolt, the pedal should be able to rotate freely with no binding.



Installing the Master Cylinder Adapter

The pushrod adapter slides in the end of the master cylinder as shown below



Firewall Adapter

Firewall adapter with studs installed shown with master cylinder spacer and gasket applied

