

HDP40-02

D&B SERIES CAM ANGLE SENSOR BASIC

Honed's Cam Angle Sensor for Honda D & B Series engines.

Allows for the use of a K-series Hall Effect sensor as a Home sensor on D & B series engines that have OE crank triggers.

This product is designed for use with aftermarket engine control units (ECUs) it is not compatible with OEM Honda ECUs (which means Hondata S100/200/300)

DISCLAIMER

This product is not intended for people unfamiliar with aftermarket engine management systems and engine sensors. If installed or set up incorrectly there is a serious risk of damage to your engine.

Honed Development Pty Ltd holds no responsibility for any damage that occurs as a result of installation of this device.

This device is intended to be installed on off-road vehicle only.

Please read through these instructions fully before attempting to install the D&B Series Cam Angle Sensor Basic

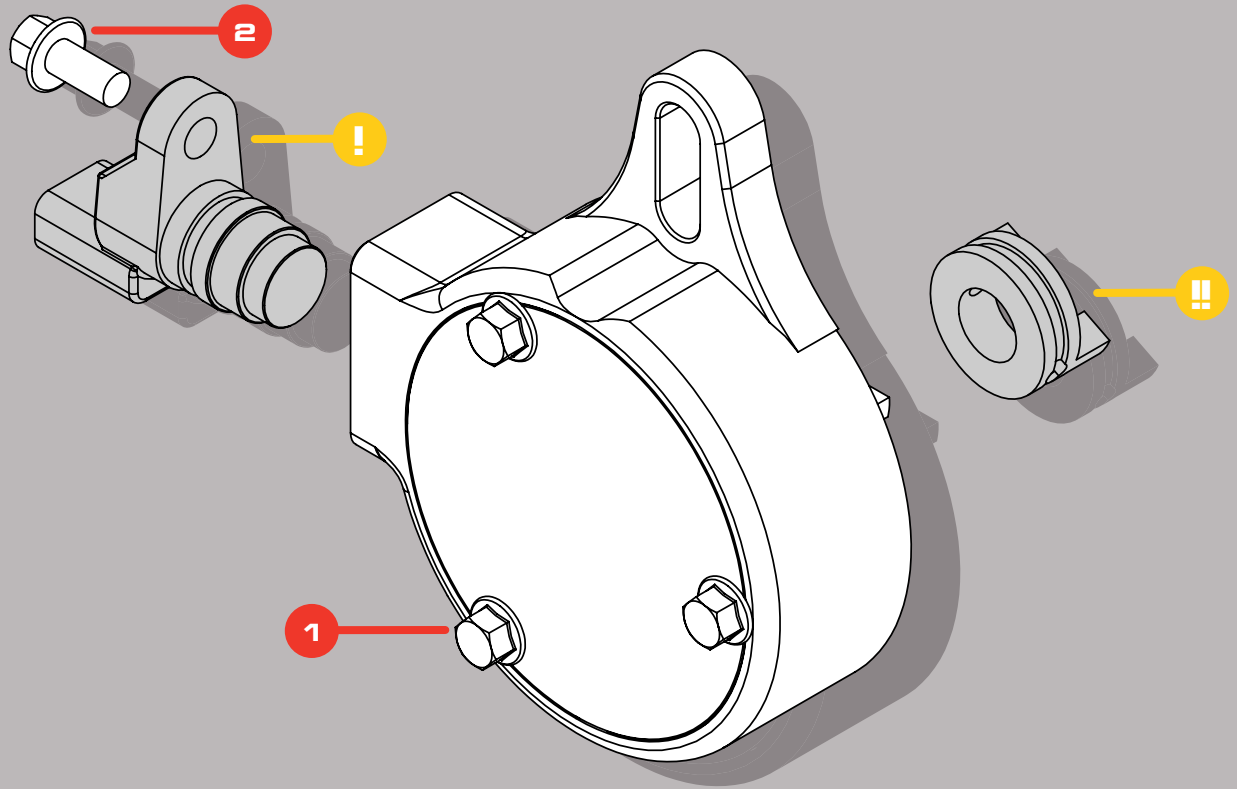

EXPLODED VIEW

HDP40-02

PARTS INCLUDED

	DESCRIPTION	QTY
1	Honed Trigger Kit Assembly	1
2	M6 x 16 Flanged Hex Screw	1

If you did not receive all items listed, or any items arrive damaged, please contact Honed Developments via e-mail;
sales@honeddevelopments.com

NECESSARY PARTS (NOT INCLUDED)

	DESCRIPTION	QTY
!	Honda Hall Effect Sensor	1
!!	Cam Drive and Components	1

- You will need a cam drive from an old Honda distributor
- You will need one Honda Hall Effect Sensor
 - The relevant part no is; **37510PNB003**
 - These can be found on a huge number of Honda vehicles produced from 2002 onward. Such as the Honda Civic, Jazz/ Fit, CR-V etc. They are used on K-series and L-series engines (among others)
 - They can typically be found mounted in the head
 - Check the length of the sensor is ~ 21mm as shown in **Figure 01**



STEPS

- 1.** Remove the original distributor from the engine.
Figure 02
- 2.** Remove the cam drive from the distributor
 - a.** Use a small screw driver to pry the Retaining Clip off the cam drive
Figure 03
 - b.** Slide Pin out
Figure 04
 - c.** Remove Cam Drive and Shim
Figure 05
 - d.** You should be left with 4 items; Shim, Pin, Retaining Clip, Cam Drive
Figure 06
- 3.** Apply engine oil to the shaft of the Honed Trigger Kit. Also apply a light amount of oil to the o-ring
Figure 07
- 4.** Assemble the shim onto the Honed Trigger Kit
Figure 08
- 5.** Re-assemble the Cam Drive, Pin and Retaining
Figure 09
Note: The drive dogs on the Cam Drive are slightly offset. The unit will only install into place with an OEM Honda cam in one orientation. You may need to remove the cam drive and rotate 180 degrees then re-install. With aftermarket cams it may be possible to end up with the trigger drive 180 degrees out
- 6.** Install Hall Effect sensor - torque the M6 flange bolts to **6Nm**
Figure 10
- 7.** Mount the unit to your engine with either a M6 (D16a3) or M8 original distributor fastener. Typically the unit is oriented with the mounting tab facing upwards.

Continue to following pages for reference figures and appendix



REFERENCE FIGURES

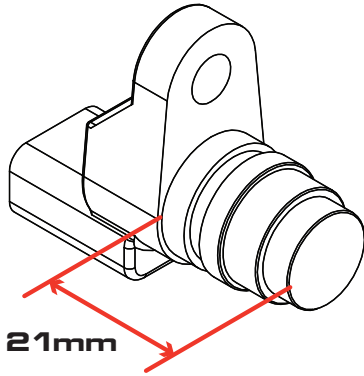

Figure 01

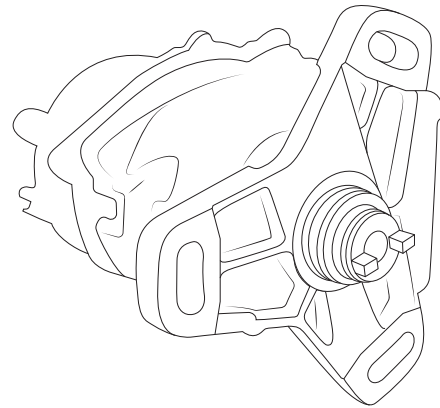

Figure 02

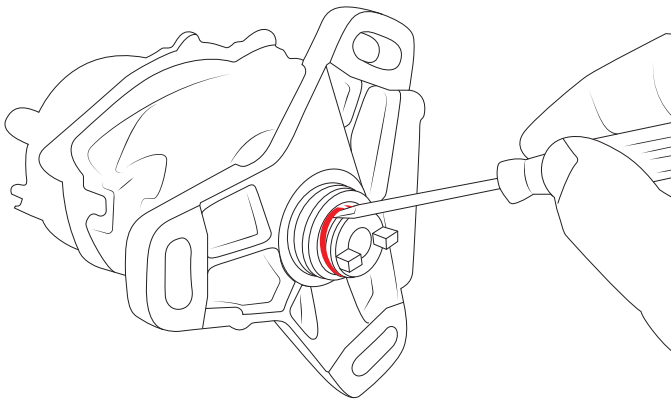

Figure 03

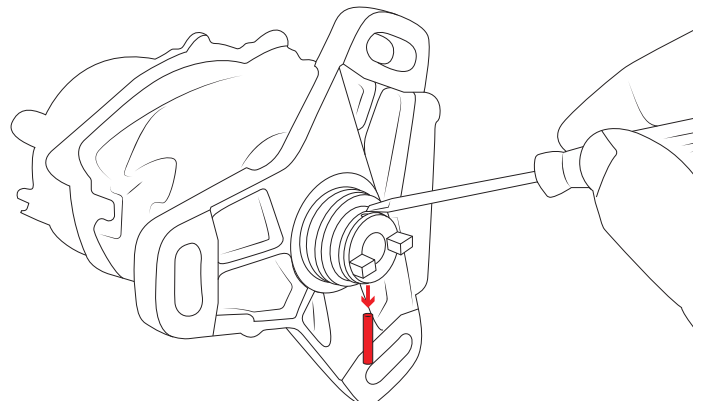

Figure 04

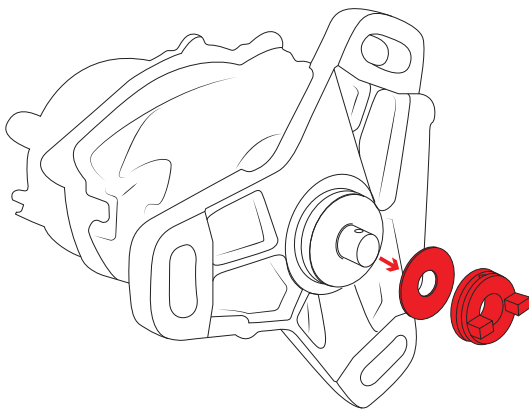

Figure 05

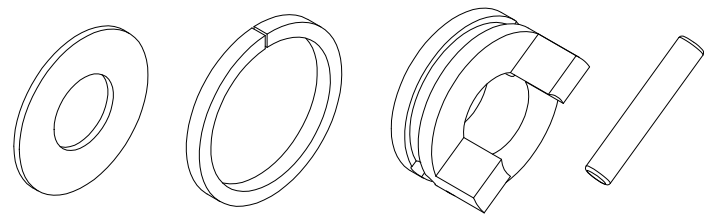

Figure 06



HDP40-02

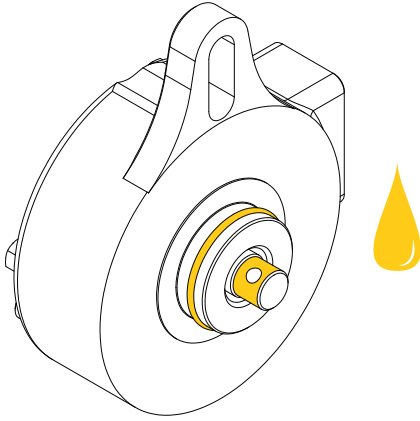

Figure 07

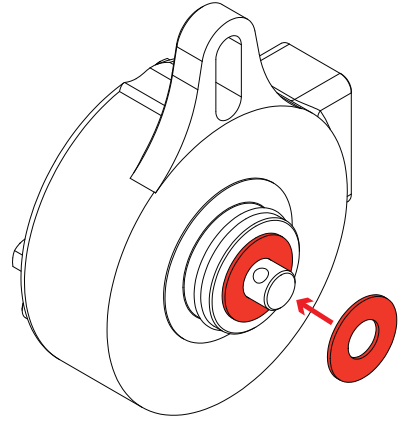

Figure 08

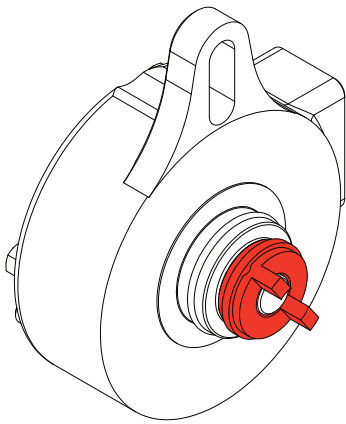

Figure 09

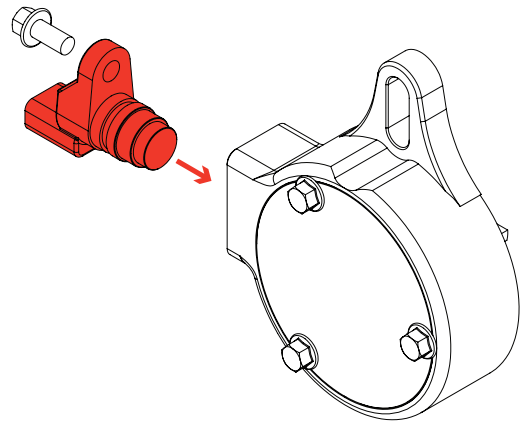
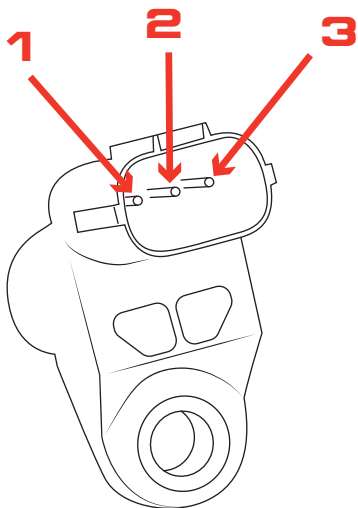

Figure 10

APPENDIX

SENSOR PLUG WIRING



1	Signal
2	Signal Ground
3	12v



ECU CONFIGURATION - GENERAL

- The Home flag is a single/ revolution (1)
- A timing light and someone that knows how to set the TDC offset angle will be required

Home Signal Location	Cam
Home Tooth Pattern	1
Trigger Sensor Type	Hall
Trigger Edge	Falling
Trigger Pull Up	Yes
Filter Level	0

ECU CONFIGURATION - HALTECH ECU

- TDC Angle Starting suggestion 109° (This needs to be checked with timing light)
- Pull up may like the strong setting



COMPLIMENTARY PRODUCTS



HONDA ENGINE PORT PLATES

Port covers to suit various iconic Honda engines.

For the purpose of protecting against unwanted objects falling into an engine during storage or when being worked on.

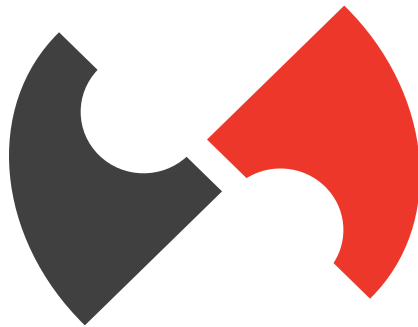

You're at the end! Thanks for trusting us!

If you have any questions please get in touch via e-mail
sales@honeddevelopments.com

We'd love to see your project. Tag us on instagram
[@honed_developments](https://www.instagram.com/honed_developments)