

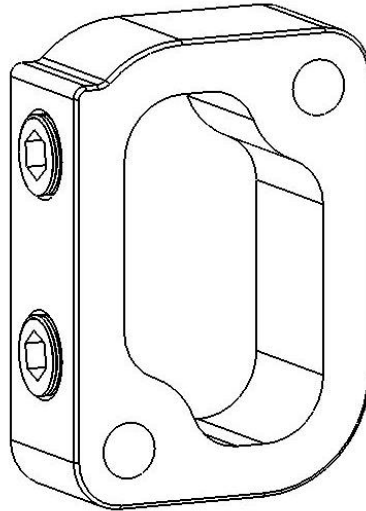

**HDP44-01**  
**D16 Coolant Spacer**



No.	Description	Quantity
1	Honed Coolant Spacer	1
2	1-8 NPT Stainless Plug Fittings	2
3	M6 x 50 Flange Head Screw ZP	2

## **Installation Notes**

- 1. We recommend using Honda bond to seal the coolant spacer to both the head and the OEM coolant outlet.**
- 2. Torque the m6 flange screws to 10 N.m (7 ft.lbs)**
- 3. We recommend applying Loctite 577 hydraulic sealant to the 1-8 NPT threads before installing either your new fittings or the supplied plugs**