

No.	Description	Quantity
1	DC5 Tie Rod Mount	1
2	"A" Insert	1
3	"B" Insert	1
4	"C" Insert	1

1

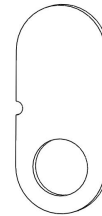

2

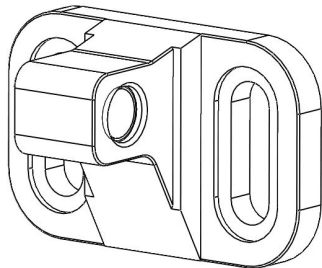
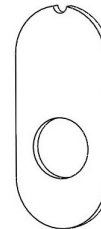

3

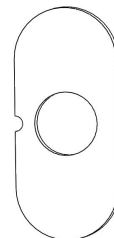

4

1. Although the tie rod mount can be installed with the steering rack installed in the vehicle with the use of special tools, we recommend planning the time to remove the rack entirely, especially if you are also looking to install the extended rack slider.
2. Refer to factory vehicle service manual for a guide to the removal and re-installation of the steering rack.
3. With the steering rack out of the vehicle, remove the inner tie rods from the original tie rod mount
4. Unbolt the original tie rod mount from the rack
5. At this point, if you are going to continue to replace the rack slider bush, do so by manipulating the rubber boot. You may need to move the rack left to right in order to get the rack slider bush out and then back in. Apply moly-grease to the rack slider.
6. Ensure the boot is centred on the steel tie rod mounting bosses.
7. Remove the rubber o-rings from the factory tie rod mounting bolts
8. Mount the Honed tie rod mount to the rack, refer to the configuration table below to determine what the orientation of the mount needs to be and which of the insert plates to use.
9. Bolt the Honed tie rod mount assembly to the steering rack, reinstall lock washer if desired.

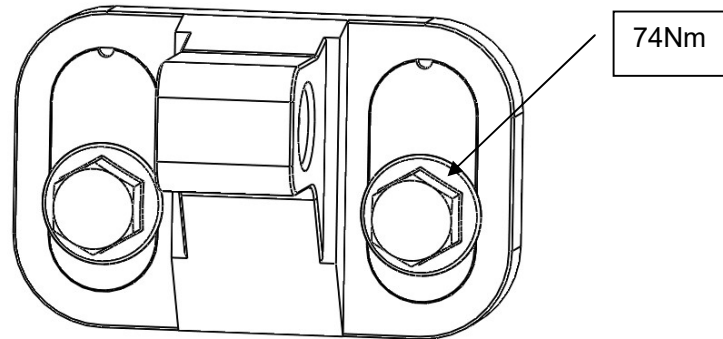

10. Install the inner tie rods, we recommend using tie rods with length shorter than stock for lowered cars. 490-495mm is a recommended length.
11. Bend over tie rod lock washers
12. Reinstall the steering rack into the vehicle and reattach outer tie rods to the steering arms, if necessary, follow guidance in factory workshop manual.
13. We recommend having your vehicle aligned with a front toe setting of "0"

Table below specifies which insert configuration we recommend based on your vehicle:

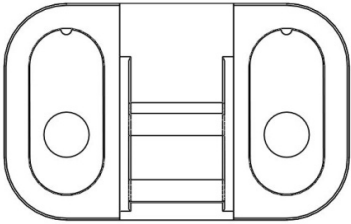
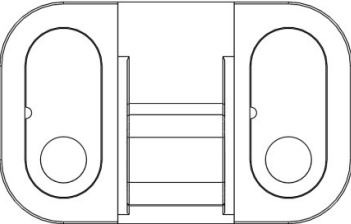
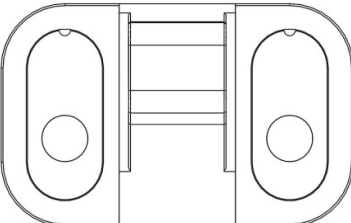
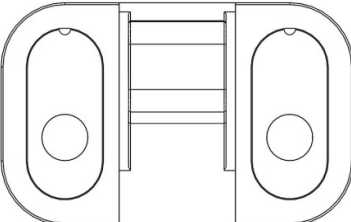
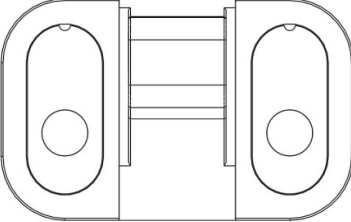
Vehicle Set Up Description	Tie Rod Mount Configuration
Inverted Tie Rod End and Stock Strut Position Steering Arm (N1 Mugen, Tien etc)	 <p style="text-align: right;">Plate B</p>
Inverted Tie Rod End and Stock Strut Position Steering Arm (N1 Mugen, Tien etc) and Roll Centre Ball Joint	 <p style="text-align: right;">Plate A</p>
Standard Tie Rod End, Stock Strut Position Steering Arm	 <p style="text-align: right;">Plate B</p>
Standard Tie Rod End, Stock Strut Position Steering Arm and Roll Centre Ball Joint	 <p style="text-align: right;">Plate B</p>
Standard Tie Rod End, Stock Strut Position Steering Arm and Roll Centre Ball Joint and high caster 5-7 deg.	 <p style="text-align: right;">Plate B</p>

Setup Table Revision: A

Note: Honed may update the recommended settings based on further testing and customer feedback. Stock strut position steering arm means that the aftermarket coilovers have replicated the steering arm position of the OEM strut (or close to it).

Reference Images

Figure 1:

