

K24 Engine Bracket Installation Notes -

Engine Block used for bracket images K24a3

Passenger Side Mount

Final torque spec for the three m10 bolts: 45 N.m (33 lb.ft)



Note the location of the supplied spacers, two spacers for the top slot and three spacers for the front slot

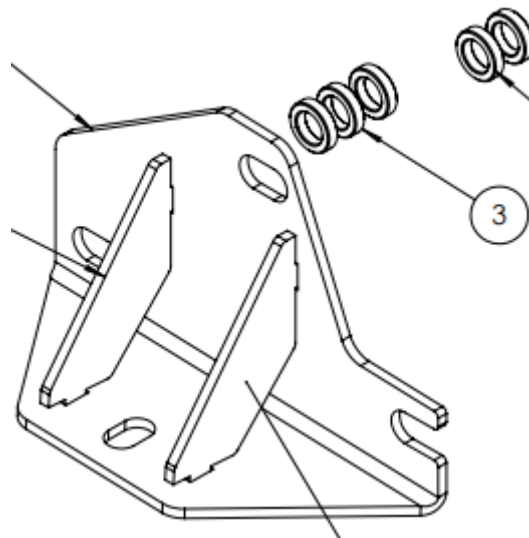

Drivers Side Mount

Final torque spec for the three m10 bolts: 45 N.m (33 lb.ft)

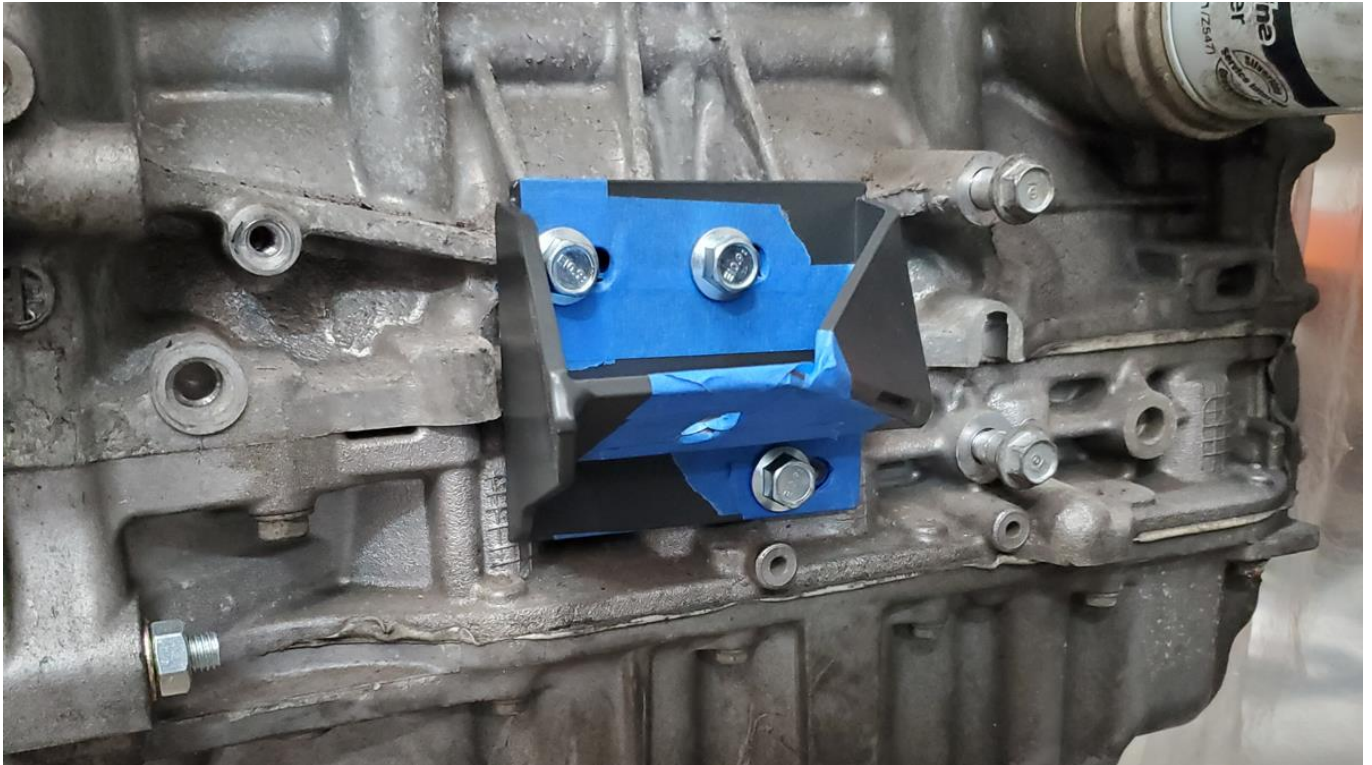

Note

To improve the range of adjustment of the driver's side engine bracket, we recommend removing material from the engine block in the location shown below. 3-5mm removed would offer a good benefit in engine angle adjustment.

