

No.	Description	Quantity
1	Angled type booster delete adapter	1
2	Pushrod	1
3	Drill template	1
4	M8 x 25mm bolt	1
5	Vacuum cap	1
6	M8 x 40 Studs	6
7	Vibra-tite Thread Locker	1
8	Firewall gasket	1

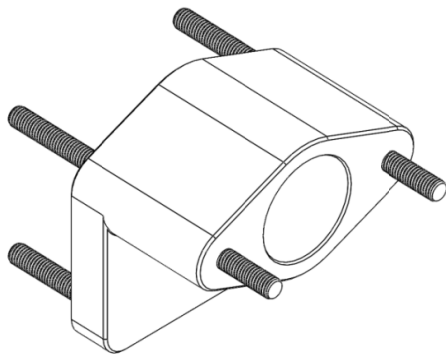

1



2



3



4

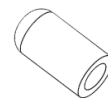

5

1. Drain the original master cylinder reservoir
2. Disconnect vacuum hose that runs from booster to intake manifold, discard hose, keep one of the hose clamps. Remove the master cylinder, take precautions not to spill any remaining brake fluid. Just push the brake lines gently out of the way.
3. Fit the supplied 10mm rubber block off cap to the now unused barb fitting on intake manifold, reuse the hose clamp.
4. Apply Vibra-tite thread locker to the end of each m8 stud, you want to apply this to the end of the stud with the shorter thread. Then install the studs as shown below. After threading in by hand, we suggest tightening the studs in place with a set of long nose pliers or vice grips holding onto the non-threaded section of the stud.

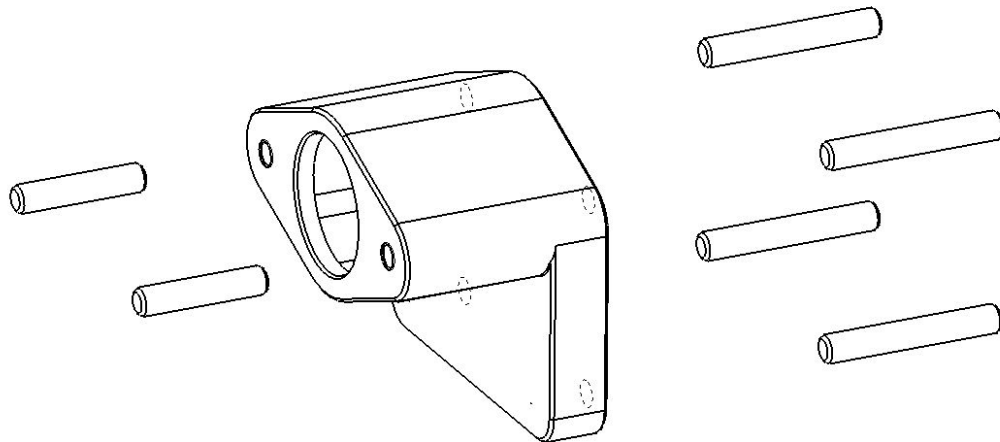

5. In the driver's side footwell, remove split pin from brake pedal clevis pin and remove the pin. Be sure to remove the drivers seat before attempting to work under the dash.
6. Remove the four nuts on the inside of the firewall that retain the booster and remove booster from engine bay side.
7. Remove the brake pedal assembly, there is a brace that must be removed to get this out
8. Drill an 8mm hole in the brake pedal 25mm (1") up from the original hole, using the provided template (refer to figure 4). The template is bolted to the original mounting hole, and then pivoted until the edge of the template aligns with the edge of the pedal. Drill hole initially with 3mm or equivalent pilot hole, then drill to final size with 8mm drill bit.
9. Remove clevis and jam nut from the brake booster. Assemble jam nut and clevis to the supplied pushrod.
10. Mount the supplied adapter to the firewall as per the original booster mounting. Attach the firewall gasket to the firewall side of the adapter. Re-use the OEM M8x1.25 nuts. Reinstall the brake pedal assembly.
11. Insert the pushrod from the engine bay side and attach to the pedal with the clevis, and OEM pin and clip through the newly created hole Push pedal to the floor so that the push rod is extended through the adapter, then offer the new master cylinder up to the pushrod taking care to ensure that the push rod is engaged into the centre of the master cylinder correctly
12. Attach the master cylinder to the adapter using the two OEM M8x1.25 nuts. At this point cycle the pedal through its full travel to check for free travel and no binding in the pushrod clevis. **Tighten all M8 hardware to 15Nm (11 ftlb)**
13. The OE lines can be gently bent into position to suit the master cylinder in its new position. Adjust the pushrod so minimal play exists at the top of the travel, and check that the brake light switch is correctly activated when pedal is pressed.
14. Bleed the braking system. **NB: Bleeding the brake system may take longer than previously, due to the lesser stroke of the master cylinder due to the change in pedal ratio.**

Notes

- We recommend sourcing and installing a GD Jazz/Fit master cylinder with this kit.