

No.	Description	Quantity
1	Booster delete adapter	1
2	Pushrod	1
3	Drill template	1
4	M8 x 25mm bolt	1
5	Vacuum cap	1
6	M8 x 40 Studs	4
7	M8 x 25 Studs	2
8	Vibra-tite Thread Locker	1

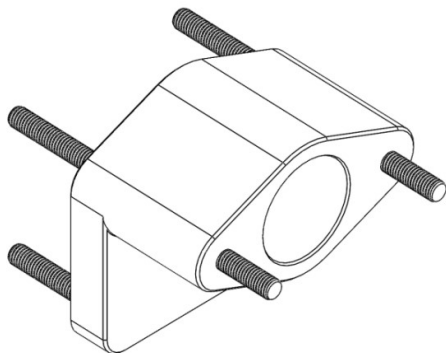

1



2



3



4



5

1. Remove the original master cylinder, take precautions not to spill brake fluid. Disconnect vacuum hose that runs from booster to intake manifold, discard hose.

2. Apply Vibra-tite thread locker to the end of each m8 stud, you want to apply this to the end of the stud with the shorter thread. Then install the studs as shown below. The two short studs go into the front face and the four longer studs go into the back face. After threading in by hand, we suggest tightening the studs in place with a set of long nose pliers or vice grips holding onto the non-threaded section of the stud.

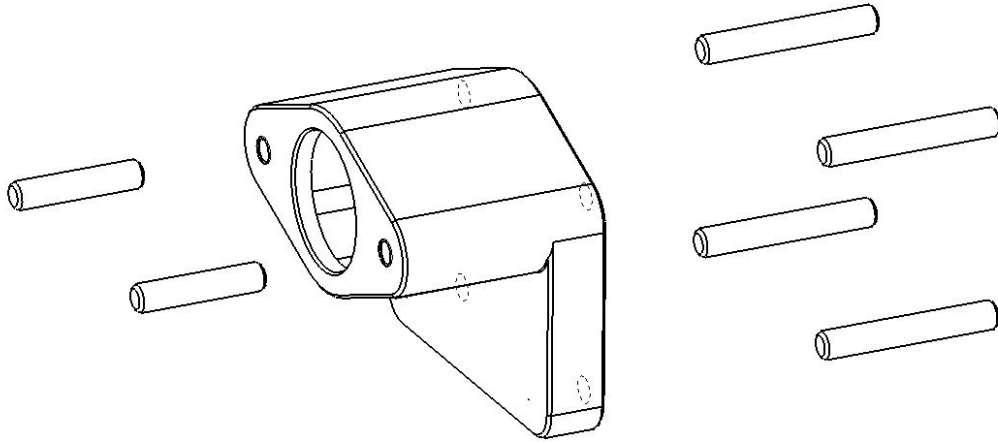

3. Fit supplied 10mm rubber block off cap to the now unused barb fitting on intake manifold. Remove 2 x hard lines that run from master cylinder to the proportioning valve.

4. In the driver's side footwell, remove split pin from brake pedal clevis pin and remove the pin. Remove brake pedal return spring.

5. Remove the four nuts on the inside of the firewall that retain the booster and remove booster from engine bay side. Remove the brake pedal using a 14mm socket and spanner.

6. Drill an 8mm hole in the brake pedal 25mm (1") up from the original hole, using the provided template refer to attached Figure 1. The template is bolted to the original mounting hole, and then pivoted until the edge of the template aligns with the edge of the pedal. Drill hole initially with 3mm or equivalent pilot hole, then drill to final size with 8mm drill bit. **Due to the many pedal variations, some modification may be required to the brake light pedal switch plate.**

7. Remove clevis and jam nut from the brake booster. Assemble jam nut and clevis to the supplied pushrod.

8. Mount the supplied adapter to the firewall as per the original booster mounting. Re-use the OEM M8x1.25 nuts. Reinstall the brake pedal and the brake pedal return spring. **On some installations the return spring connection to pedal may need to be modified by drilling an additional hole further from the clevis.**

9. Insert the pushrod from the engine bay side and attach to the pedal with the clevis, and OEM pin and split pin through the newly created hole. Push pedal to the floor so that the push rod is extended through the adapter, then offer the new master cylinder up to the pushrod taking care to ensure that the push rod is engaged into the centre of the master cylinder correctly.

10. Attach the master cylinder to the adapter using the two OEM M8x1.25 nuts on the studs provided on the adapter. At this point cycle the pedal through its full travel to check for free travel and no binding in the pushrod clevis. **In some installations a small amount of material may need to be ground away from the upper area of the original hole in the firewall to avoid contact with the pushrod. Tighten all M8 hardware to 15Nm (11 ftlb)**

11. Make and fit suitable brake hard lines to connect from brake master cylinder to proportioning valve (not provided). On LHD installations the OE lines can be gently bent into position to suit the new master cylinder. Brake hoses are 3/16" tubing and fittings are M10x1.0 inverted flare. Adjust pedal free play such that minimal play exists at the top of the travel, and the brake light switch is correctly activated when pedal is pressed.

12. Bleed the braking system. **NB: Bleeding the brake system may take longer than previously, due to the lesser stroke of the master cylinder due to the change in pedal ratio.**

Table below specifies which type of master cylinder should be used for your brake setup:

Master Cylinder Recommendation Guide - Any 1996-2000 Civic master cylinder may be used

Brake set up	Master Cylinder Diameter
Oem Honda front and rear calipers with 262mm front rotors or smaller	13/16"
Oem Honda front and rear calipers with 282mm front rotors or greater	7/8"
Aftermarket front calipers, Honed Porsche kit, Wilwood, Spoon, Stoptech etc	7/8"

Example Images

