

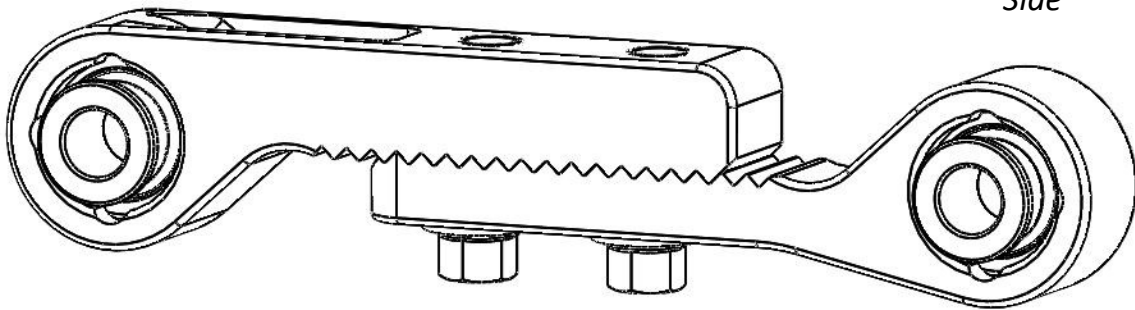

**Adjustable Toe Arm
Civic and Integra (94-01) –
HDP12-03**

Chassis Side

*Trailing Arm
Side*



**Right Hand Adjustable Toe Arm
Shown**

No.	Description	Quantity
1	Inner Toe Arm	2
2	Outer Toe Arm	2
3	Spacer	4
4	M8x25 Flange Head Bolt	4

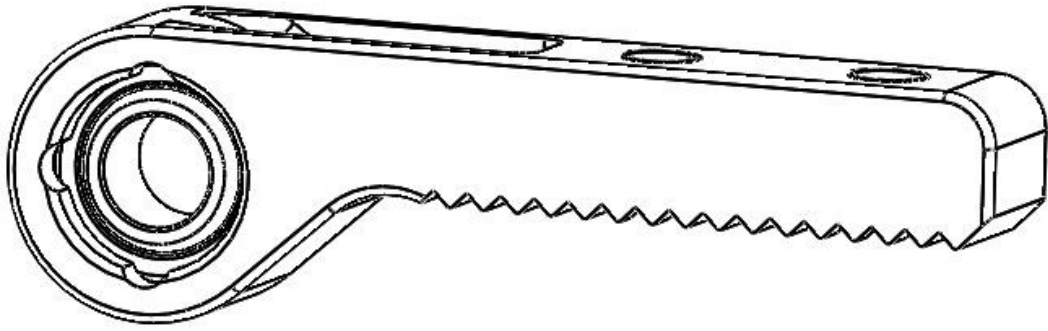

Right Hand Shown

1

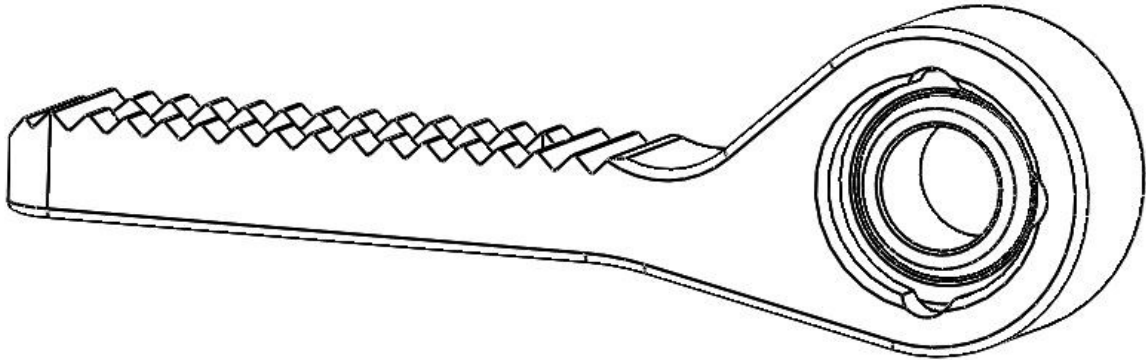

Right Hand Shown

2

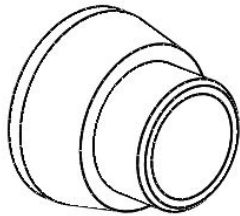

3

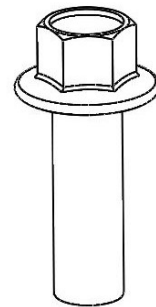

4

1. Raise the rear of the vehicle, and support on jack stands.
2. Loosen the existing Toe Arm fasteners on both the chassis and trailing arm ends.
3. Remove the two large bolts retaining the trailing arm RTA bush to the chassis, 17mm socket.
4. Remove the existing Toe Arm
5. Install the Honed Adjustable Toe Arm as shown:

Note: We recommend starting with the arm length adjustment one increment in from full extension. This allows you to have one incremental toe out adjustment available



6. Tighten Toe Arm fastener in the trailing arm to 64N.m (47 lb.ft)
7. Re-install the trailing arm RTA bush bolts and torque to 64N.m (47 lb.ft)
8. Torque the Toe Arm Fasteners, 12mm socket required

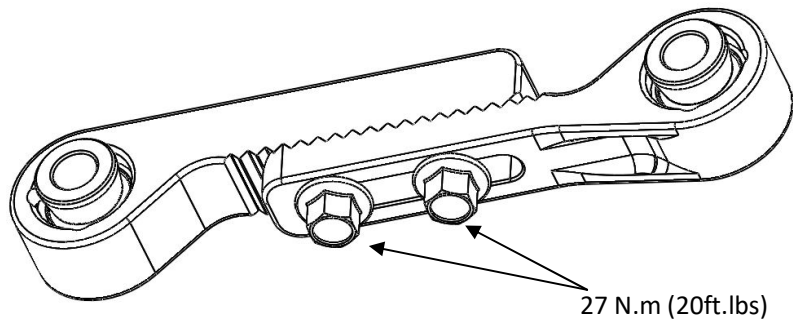

9. Check that there is no fouling or binding of the suspension at full bump or droop by cycling the suspension upward and downward with a jack placed beneath the hub.
10. After installation a wheel alignment must be performed, see further down in this document for Honed's recommendations.
11. The torque setting for the chassis side bolt is 64N.m (47 lb.ft)
12. If you also have Honed's eccentric toe adjustment kit, please refer to the separate instruction sheet for that product.

Note 1: Honed recommend using the body-side adjustment to set your desired rear toe alignment setting and to use the teeth-adjustment of the toe arm for making rear to changes to impact the handling of your car when at a motorsport event and alignment equipment is not available.

Handling Issue	Recommended Adjustment
Car is tight, understeering	Adjust length of Toe Arm one notch toward -ve (longer by 4mm)
Car is loose, oversteering	Adjust length of Toe Arm one notch toward +ve (shorter by 4mm)

Note 2: Each tooth step is equal to 4mm, adjusting the length of the toe arm will change your rear toe setting by 0.3° the table below converts this to a toe change as measured at the rim.

	Hub Toe Angle	Toe Change 15" (190mm radius)	Toe Change 17" (215mm radius)
+/- Range	0.3°	1mm (3/64")	1.1mm (0.0433")

Note 3: These components are intended for race use only, and will require regular inspection and maintenance. Honed will not be held responsible for any misuse of the components.

Honed Alignment Recommendations

Here are our alignment recommendations to help you hit the track with a great starting point

After getting your car aligned, keep the alignment sheet for your records
if you don't get a print out then fill in the "Final Values" column

	Honed Recommendation	Final Values
Front Axle		
Individual Toe	0mm	
Camber	-2.5 degrees	
Castor	+1 to +4 degrees	
Rear Axle		
Individual Toe	+1.5mm (toe in)	
Camber	-2 degrees	

The alignment settings above are to suit Honda Civic and Integra vehicles from 88'-01' and are intended as a starting point only.
Front castor is listed as a range, if you have components that increase castor consider that this can have a detrimental effect on bumpsteer and adjustable outer tie rods can be beneficial.