

# HONED

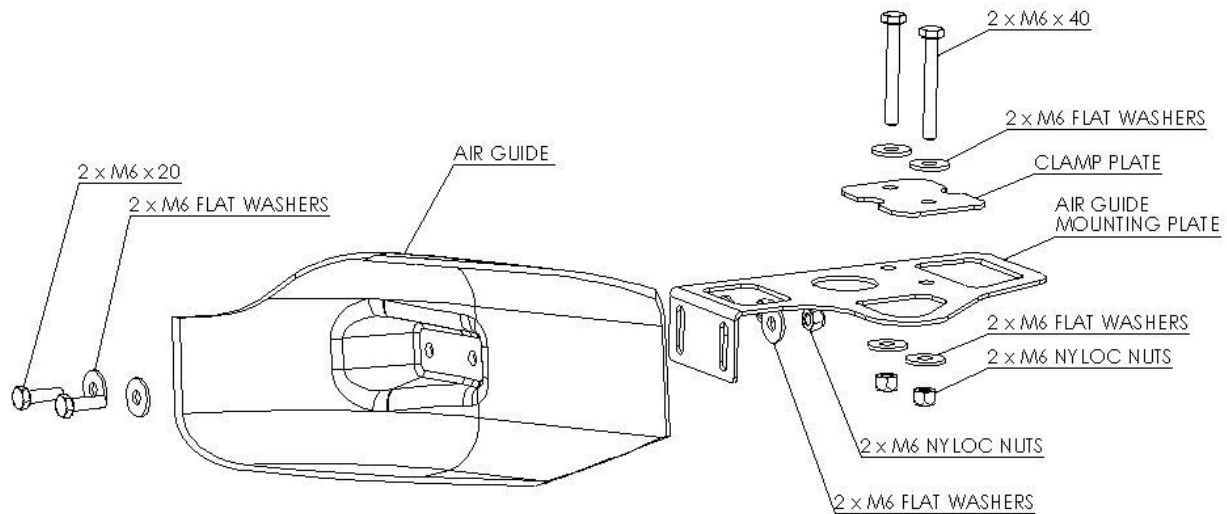

LHS Assembly Shown

## Air Guide Installation Instructions: S2000

1. Jack up car and place on jack stands
2. Assemble air guide mounting bracket to lower control arm on either side of the vehicle using supplied M6x40mm bolts passing through the circular hole in the control arm, with nylock nuts and washers on both sides, and the clamp plate on top of the control arm. The folded part of the bracket should **point down**, with the straight edge of the mounting bracket on the inboard side.
3. The clamp plate should be oriented with the wider side toward the outside of the car, and the inboard edge of the clamp plate should align with the inner edge of the control arm.
4. Fit air guide to air guide bracket with supplied M6x16mm bolts and nylock nuts and the stainless steel clamping plate on the front side.
5. Adjust angle of air guide such that mounting face of air guide is approximately perpendicular to vehicle centreline, and such that air guide is protruding into the free stream below the vehicle with sufficient ground clearance. Check that air guide is not fouling any suspension parts by turning the steering from lock to lock.

The outermost tip of the air guide should be 5-10mm from the head of the lower shock bolt, to ensure clearance to the wheel rim at full lock. The recommended height for the

lowermost edge of the guide is 70-80mm above ground level, however this will vary depending on your ride height.

6. Tighten all hardware and then fit 2 x Honed stickers to over mounting area of brake air guide
7. Lower car off jack stands

### Reference Images



